

お客様各位

株式会社日出電機製作所
営業部
TEL: 03-3860-8661
FAX: 03-3860-8660

発行: 2022年2月吉日

当社一部製品生産終了のお知らせ

拝啓

貴社ますますご清祥のこととお喜び申し上げます。平素は格別のご高配を賜り、厚くお礼申し上げます。

さて、誠に勝手ながらこの度下記製品の生産・販売を終了させていただくこととなりましたので当書面にてご連絡させていただきます。

今後とも変わらぬご愛顧、お引き立ての程宜しくお願い申し上げます。

敬具

－ 記 －

1. 対象品名

- ・15KAR シリーズ
- ・25KAR/250GAR シリーズ
- ・50KAR/500GAR シリーズ

2. 販売終了理由

生産数量減少及び継続生産困難の為

3. 代替推奨品

大変申し訳有りませんが、代替品は御座いません。
カタログをご参考の上、同クラス製品である下記製品への設計変更をご検討頂ければ幸いです。

250GH/350GH シリーズ <https://www.hinodedenki.co.jp/products/250gh350gh/>

660GH シリーズ <https://www.hinodedenki.co.jp/products/660gh/>

※別途で比較資料を送付致します。

4. 生産・販売中止スケジュール

2022年8月末日受注及び、ご指定納期: 2022年12月末日まで

ご不明点につきましては、当社までお問い合わせください。
誠に恐れ入りますが、事情ご賢察の上ご協力の程宜しくお願い申し上げます。

以上

15KARシリーズ																		
型式	定格電流 A	定格電圧 遮断容量	溶断 I^2t A ² s	全遮断 I^2t (A ² s) at AC150V	電力損失 W	外形						Fig						
						A	B	C	D	E	T							
15KAR100	100	AC150V 50kA DC100V 50kA L/R=5ms	540	4,000	5	74	53	32	10	36	5	1						
15KAR150	150		1,400	10,000	7.8													
15KAR200	200		2,100	16,000	11.5													
15KAR250	250		3,100	24,000	14.8													
15KAR300	300		4,800	36,000	18													
15KAR400	400		8,600	65,000	24	84	63	32	10	36	5							
15KAR600	600		18,000	140,000	34													
15KAR800	800		34,000	250,000	48								92	65	32	10	45	8

250GHシリーズ														
型式	定格電流 A	定格電圧 遮断容量	溶断 I^2t A ² s	全遮断 I^2t (A ² s) at AC250V-100kA	電力損失 W	外形								Fig
						A	B	C	D	E	F	G	H	
250GH-100	100	AC250V 100kA DC250V 100kA L/R=10ms	530	4,200	11	55	41	25	6.5	9.5	17.5	18	2	
250GH-125	125		820	6,700	14									
250GH-160	160		1,200	10,190	18									
250GH-200	200		2,100	18,070	24									
250GH-250	250		3,300	30,810	34									
250GH-315	315		6,000	46,110	35	87	60	30	10.8	16	31	35		
250GH-350	350		7,400	61,990	52									
250GH-400	400		11,000	146,420	45									
250GH-450	450		13,500	162,120	50									
250GHW500	500		24,000	200,880	58									86
250GHW630	630	30,000	364,400	76										
250GHW710	710	43,000	584,670	82										
250GHW800	800	53,000	647,480	93										

■外形図
Fig.1

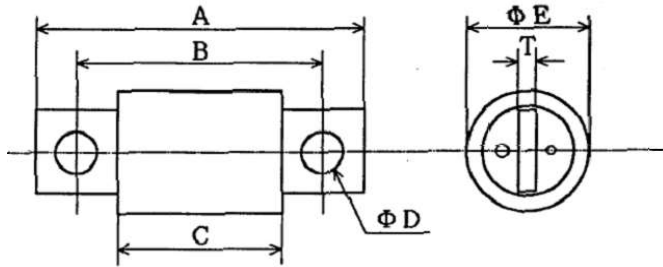

Fig.2

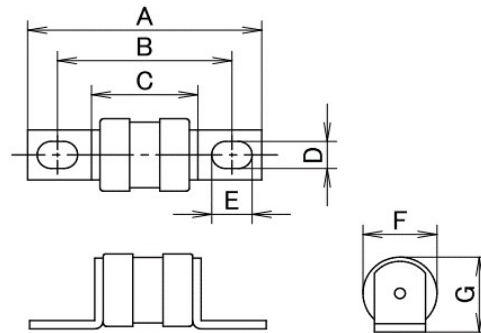
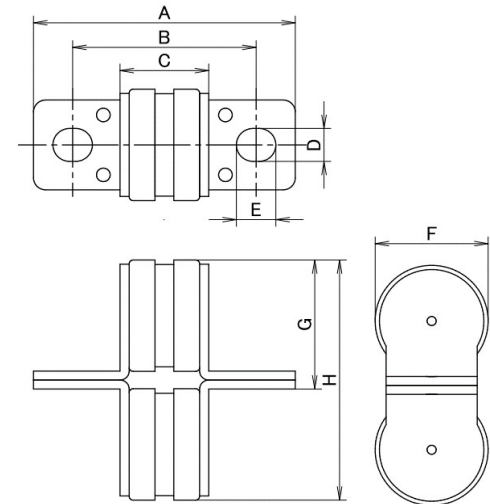
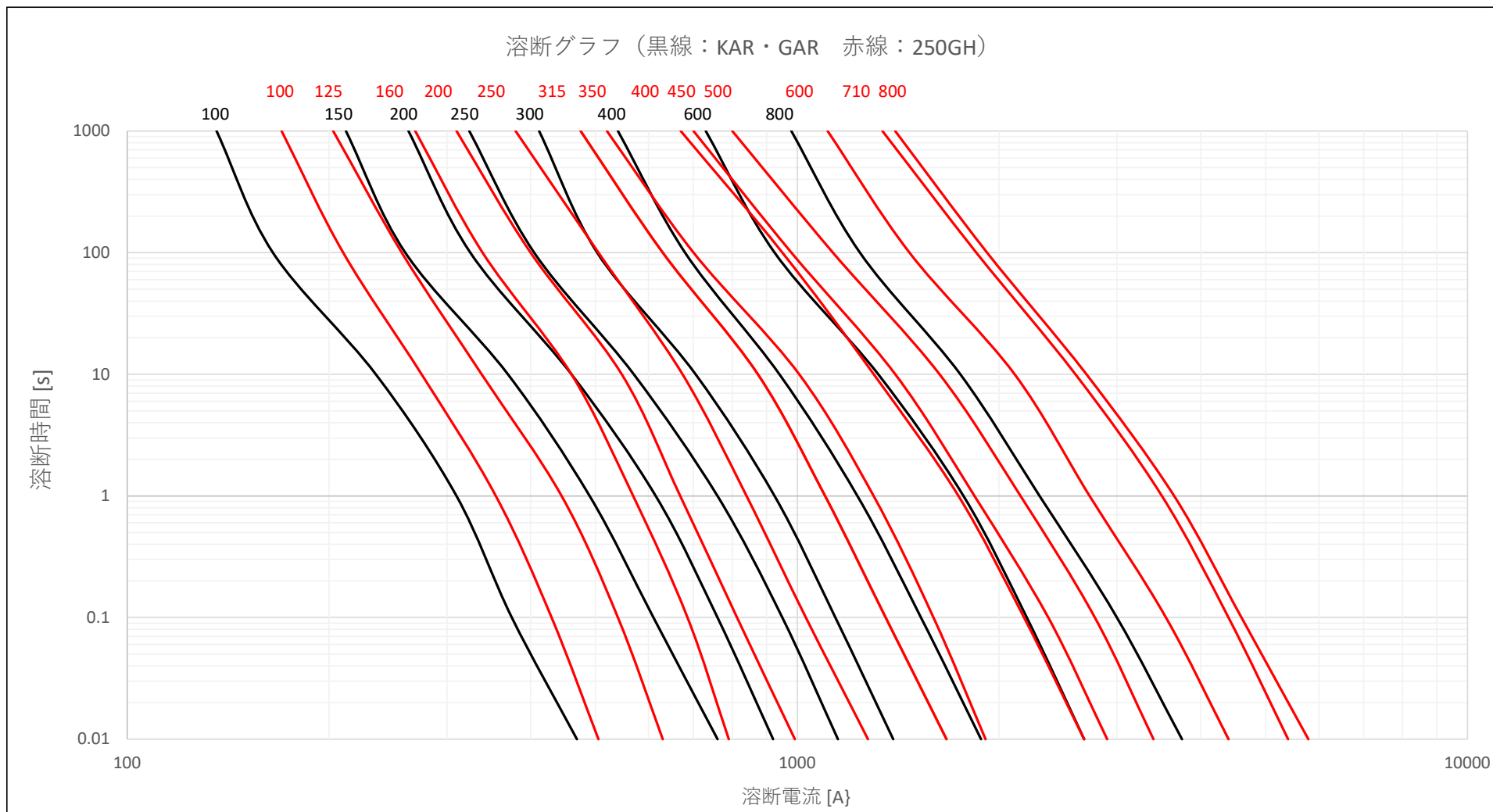

Fig.3



■ 溶断特性



25KAR/250GARシリーズ												
型式	定格電流 A	定格電圧 遮断容量	溶断 ¹ t A ² s	全遮断 ¹ t (A ² s) at AC250V	電力損失 W	外形						Fig
						A	B	C	D	E	T	
25KAR50 250GAR50	50	AC250V 50kA DC200V 50kA L/R=5ms	150	1,100	4	80	59	38	10	32	4	1
25KAR75 250GAR75	75		350	2,600	6.3							
25KAR100 250GAR100	100		620	4,600	8.5							
25KAR150 250GAR150	150		1,400	10,000	15							
25KAR200 250GAR200	200		2,400	17,000	21	80	59	38	10	36	5	
25KAR250 250GAR250	250		3,100	22,000	26							
25KAR300 250GAR300	300		5,600	42,000	28	98	71	38	11	45	8	
25KAR400 250GAR400	400		8,600	65,000	40							
25KAR500 250GAR500	500		13,000	97,000	46							
25KAR600 250GAR600	600		22,000	160,000	49							
25KAR800 250GAR800	800		63,000	460,000	53	98	71	38	13	60	13	

250GHシリーズ														
型式	定格電流 A	定格電圧 遮断容量	溶断 ¹ t A ² s	全遮断 ¹ t(A ² s) at AC250V-100kA	電力損失 W	外形								Fig
						A	B	C	D	E	F	G	H	
250GH-050	50	AC250V 100kA DC250V 100kA L/R=10ms	132	1,060	5.5	55	41	25	6.5	9.5	17.5	18	2	
250GH-063	63		208	1,680	6.5									
250GH-080	80		370	2,800	8									
250GH-100	100		530	4,200	11									
250GH-125	125		820	6,700	14	78	57	29	9	14	24.5	26		
250GH-160	160		1,200	10,190	18									
250GH-200	200		2,100	18,070	24	87	60	30	10.8	16	31	35		
250GH-250	250		3,300	30,810	34									
250GH-315	315		6,000	46,110	35									
250GH-350	350		7,400	61,990	52									
250GH-400	400		11,000	146,420	45	86	61	30	11	13	37	42		
250GH-450	450		13,500	162,120	50									
250GHW500	500		24,000	200,880	58	86	61	30	11	13	37	44		82
250GHW630	630		30,000	364,400	76									
250GHW710	710		43,000	584,670	82									
250GHW800	800		53,000	647,480	93									

■外形図

Fig.1

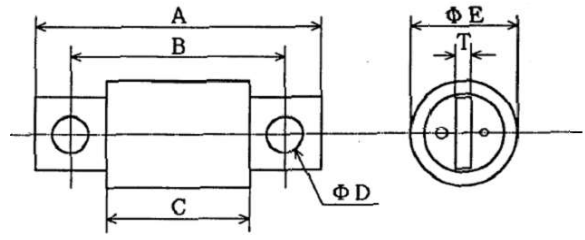

Fig.2

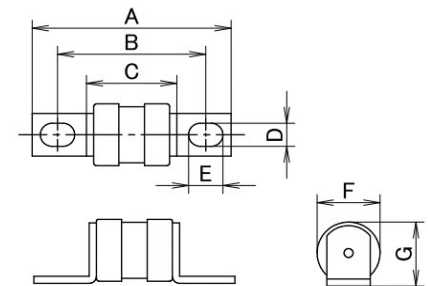
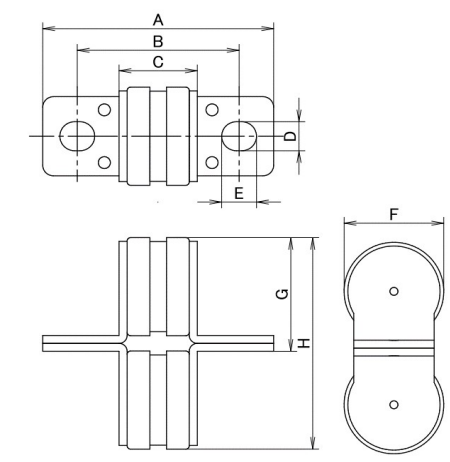
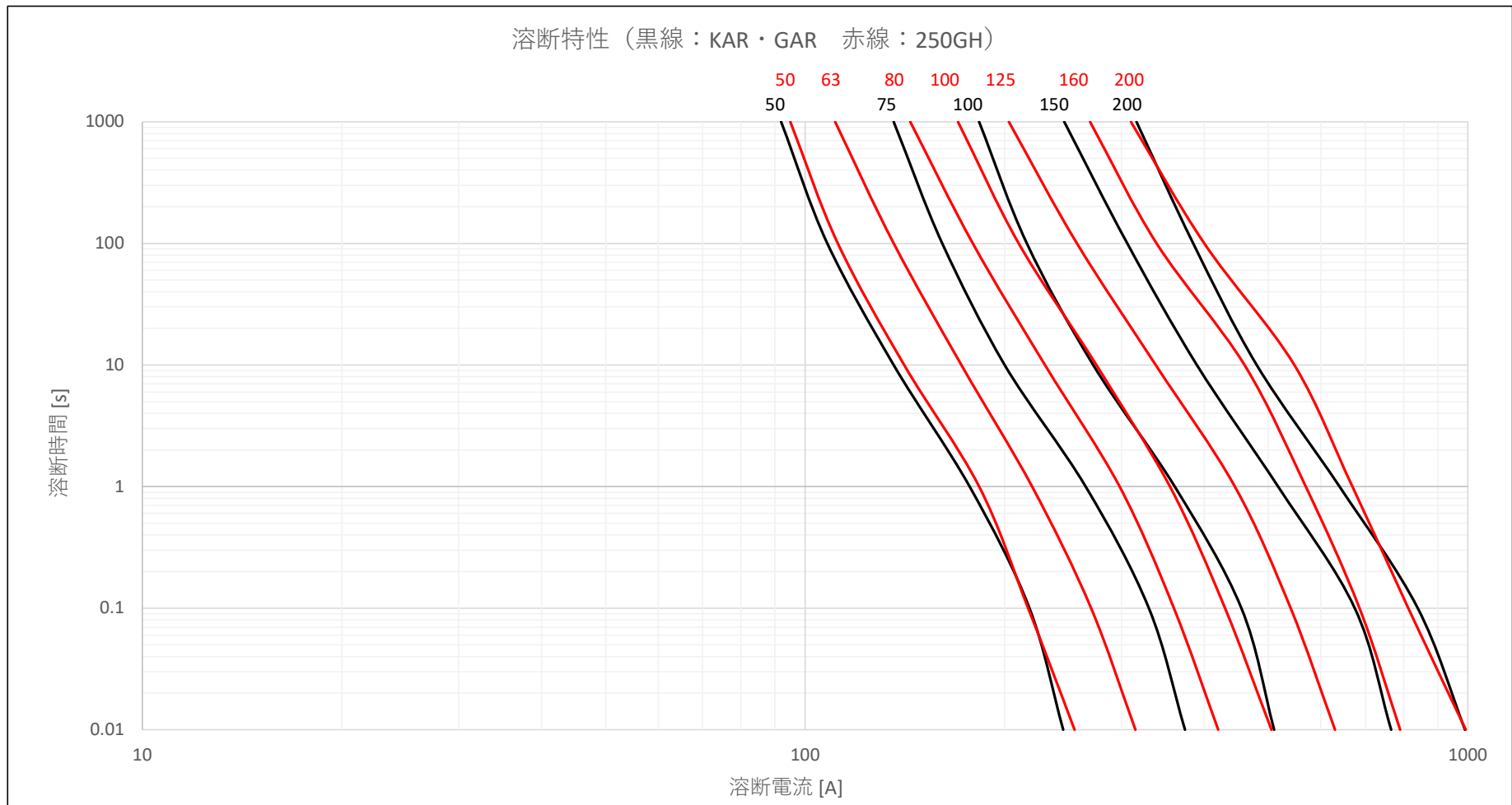

Fig.3



■ 溶断特性



溶断特性 (黒線: KAR・GAR 赤線: 250GH)

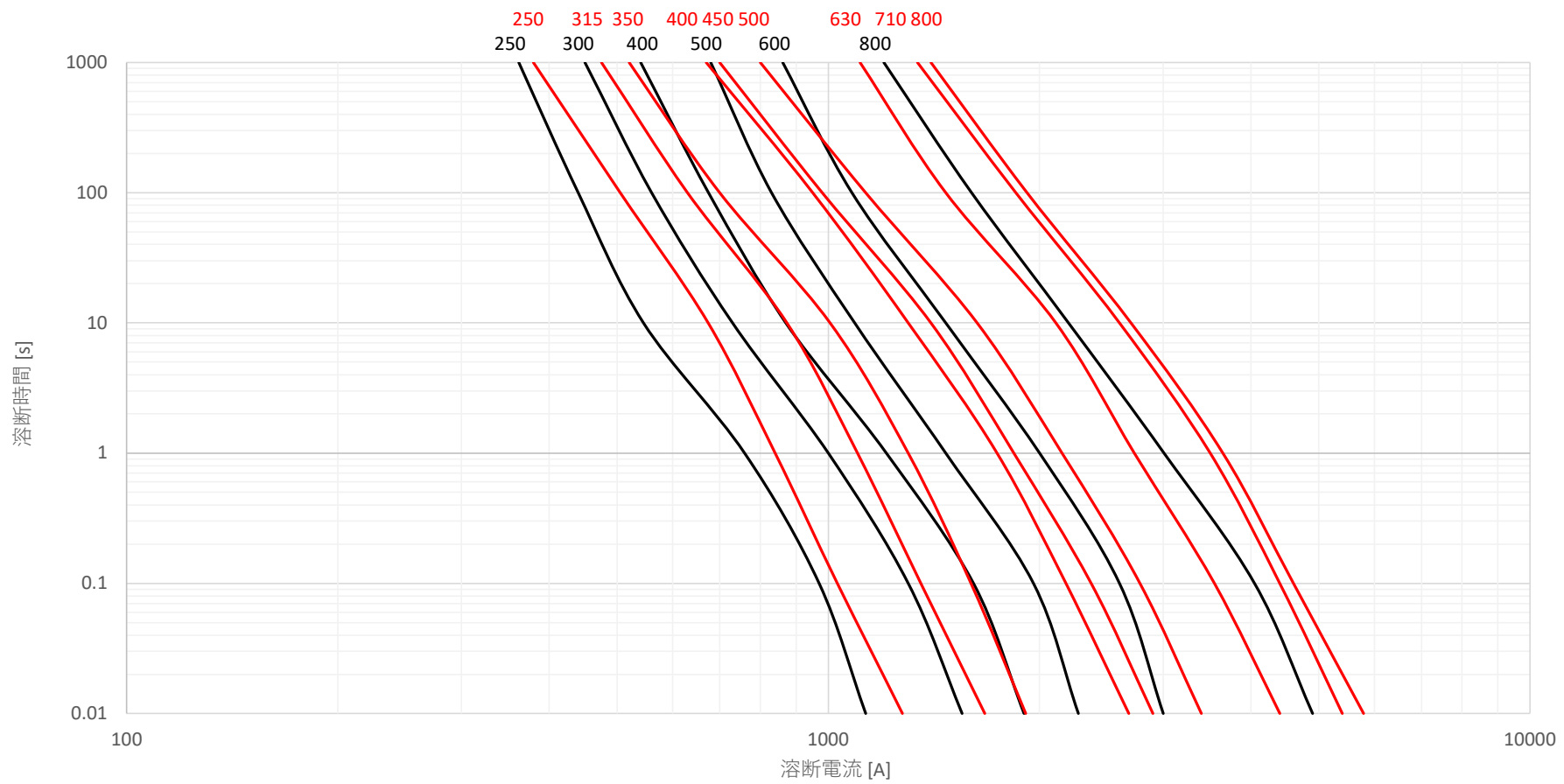

50KAR/500GARシリーズ																		
型式	定格電流 A	定格電圧 遮断容量	溶断 ¹ t A ² s	全遮断 ¹ t (A ² s) at AC500V	電力損失 W	外形						Fig						
						A	B	C	D	E	T							
50KAR30 500GAR30	30	AC500V 50kA DC400V 50kA L/R=5ms	90	700	4.2	112	91	60	10	36	5	1						
50KAR50 500GAR50	50		240	1,800	8													
50KAR75 500GAR75	75		540	4,200	12													
50KAR100 500GAR100	100		960	7,000	16													
50KAR150 500GAR150	150		2,100	18,000	22													
50KAR200 500GAR200	200		3,900	35,000	28													
50KAR250 500GAR-250	250		7,000	50,000	40													
50KAR300 500GAR300	300		8,600	70,000	47								120	93	60	11	45	8
50KAR400 500GAR400	400		17,000	150,000	47													
50KAR500 500GAR500	500		22,000	190,000	60								120	93	60	11	50	8
50KAR600 500GAR600	600		41,000	370,000	64													
50KAR800 500GAR800	800		93,000	580,000	85								120	93	60	13	50	13

660GHシリーズ																							
型式	定格電流 A	定格電圧 遮断容量	溶断 ¹ t A ² s	全遮断 ¹ t (A ² s) at AC250V-100kA	電力損失 W	外形								Fig									
						A	B	C	D	E	F	G	H										
660GH-032	32	AC660V 100kA DC660V 100kA L/R=10ms	74	920	6	76.7	62.7	46	6.5	9.5	18.5	18	-	2									
660GH-040	40		100	1,350	7																		
660GH-050	50		167	2,230	9																		
660GH-063	63		300	3,910	12																		
660GH-080	80		400	5,310	17																		
660GH-100	100		670	8,790	22																		
660GH-125	125		1,200	15,630	25																		
660GH-160	160		2,100	27,760	35										98	78	50	9	14	25	26	-	
660GH-200	200		3,300	47,490	40																		
660GH-250	250		6,000	69,450	50										108	81	51	10.5	16	31	35	-	
660GH-315	315		7,400	93,750	80																		
660GH-350	350		11,000	167,930	70										107	81.5	51	11	13	37	40	-	
660GH-400	400		14,000	186,240	75																		
660GH-450	450		24,000	283,420	85																		
660GH-500	500		29,000	416,530	95										107	81.5	51	11	13	37	43	80	3
660GH-630	630		42,000	669,720	105																		
660GH-710	710	51,000	739,930	115																			

■外形図

Fig.:

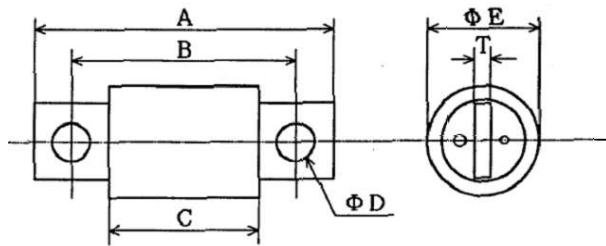

Fig.2

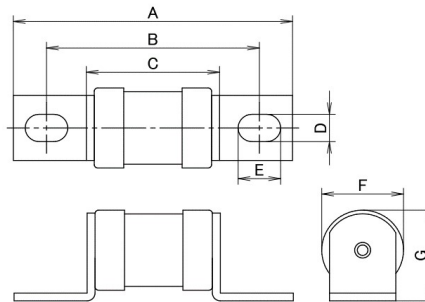
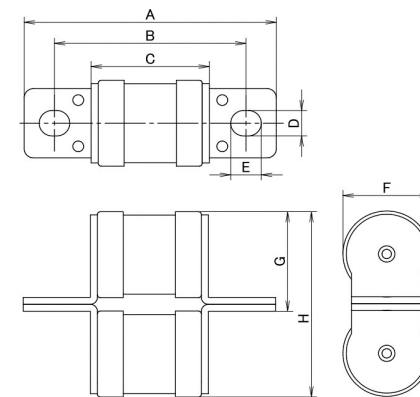
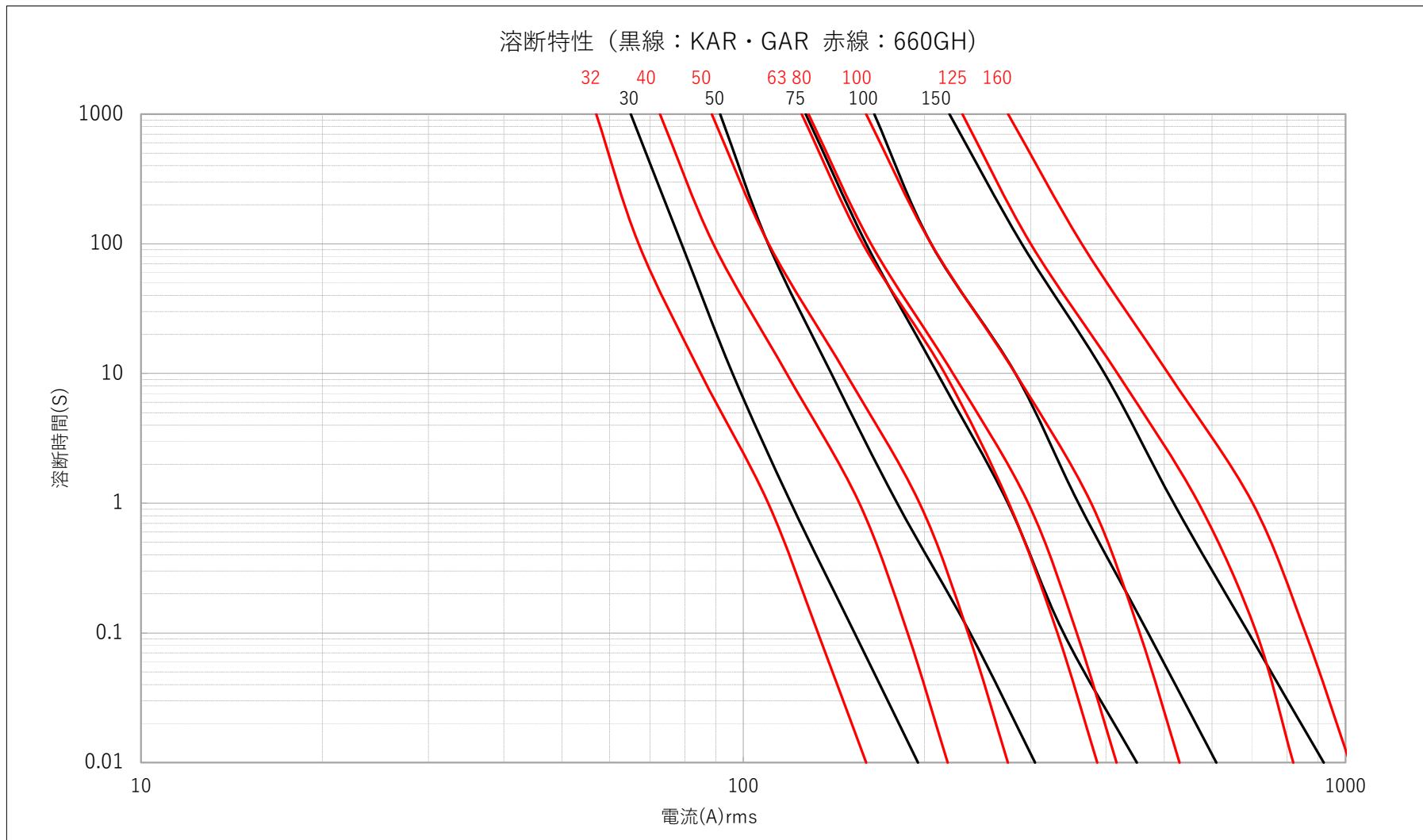

Fig.3



■ 溶断特性



溶断特性 (黒線 : KAR・GAR 赤線 : 660GH)

